

BURIN by Patricia Urquiola 2018



Burin is a symbolic tribute to traditional wood carving tools.

The unmistakable silhouette of the base runs through this extension of the collection to include a new table with a central base, available in different heights and a double version for large surface areas.

Conceived for both homes and community spaces, the new Burin table gives continuity to the family that was launched in 2011 with the side table designed by Patricia Urquiola.

PATRICIA URQUIOLA



Patricia Urquiola was born in Oviedo (Spain) and currently lives and works in Milan.

She graduated from the Faculty of Architecture at the Technical University of Madrid in 1989, after completing a thesis with Achille Castiglioni. From 1990 to 1992, she was assistant lecturer to both Achille Castiglioni and Eugenio Bettinelli at the Milan Polytechnic and the E.N.S.C.I. in Paris.

Between 1990 and 1996, she worked in the new product development office of De Padova and, with Vico Magistretti, signing the products: “Flower”, “Loom sofa”, “Chaise” and “Chaise Longue”.

From 1993 to 1996, she worked with the architects de Renzio and Ramerino and was engaged in architectural design, showrooms, restaurants and franchising (Maska/Italy, Tomorrowland Stores/Japan, Des Pres/France).

In 1996 she became head of the design department at Lissoni Associati, working for Alessi, Antares-Flos, Artelano, Boffi, Cappellini, Cassina and Kartell, among others.

Her products were selected for the Italian Design 2001 exhibition. In 2001 she was chair of the jury for the 19th CDIM Design Award and was lecturer at the Domus Academy.

She is currently working in her own practice in Milan in the fields of design, exhibitions, art direction and architecture. Patricia Urquiola works for Alessi, B&B, Kartell, Molteni, Moroso, Coalesse and VICCARBE.

DIMENSIONS

HEIGHT 74

BUD60 round 60

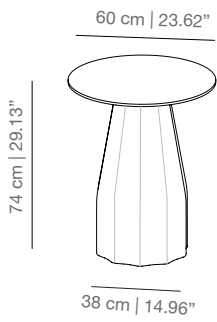

BUD70 round 70

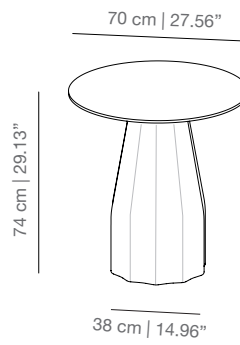

BUD80 round 80

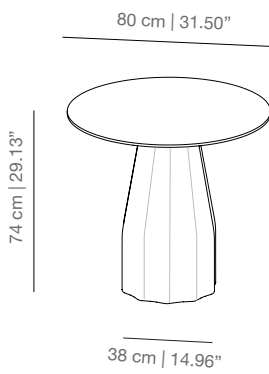

BUD100 round 100

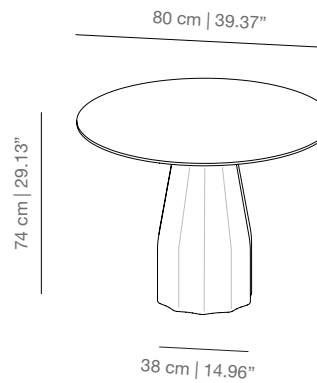

BUD120 round 120

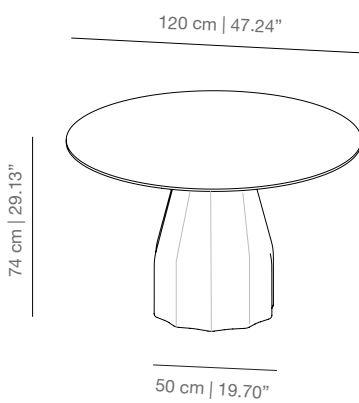

BUD150 round 150

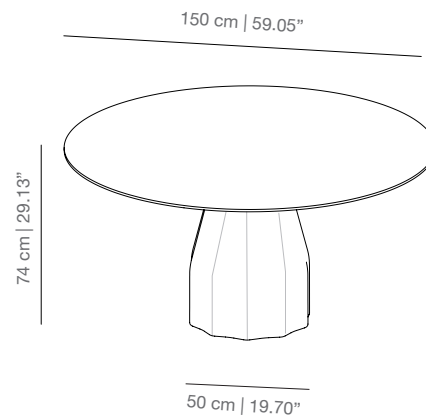

DIMENSIONS

HEIGHT 74

BUC70 70x70

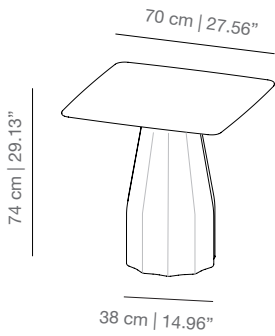

BUC80 80x80

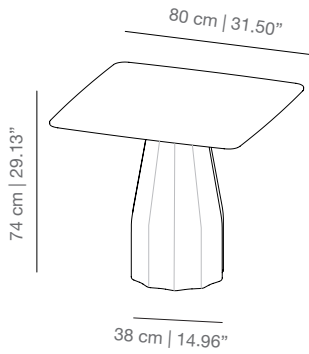

BUC90 90x90

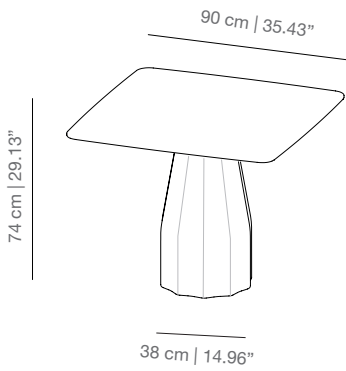

BUC100 100x100

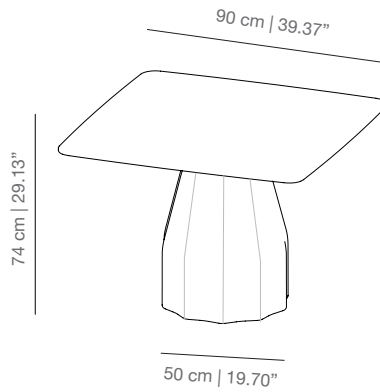

BUC140 140x140

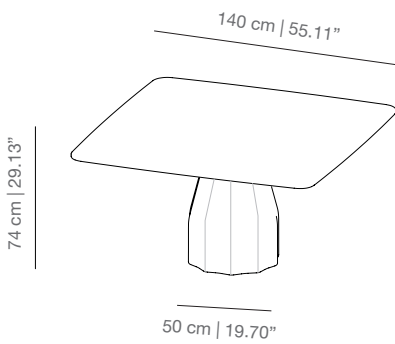

BUC240 240x120

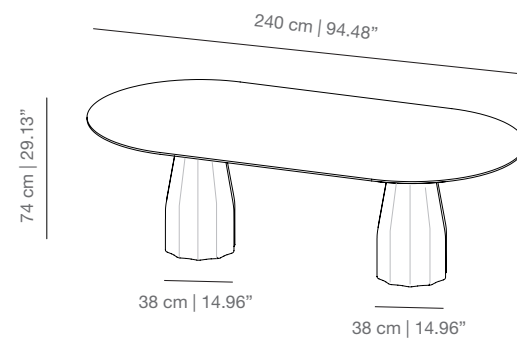

BUC300 300x150

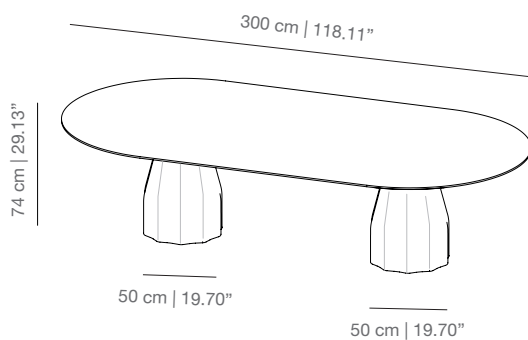

DIMENSIONS

HEIGHT 102

BUD60H round 60

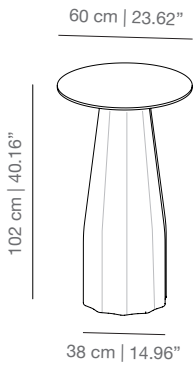

BUD70H round 70

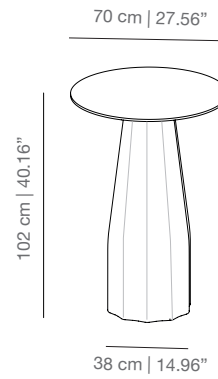

BUD80H round 80

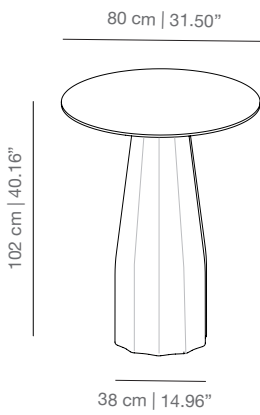

BUD100H round 100

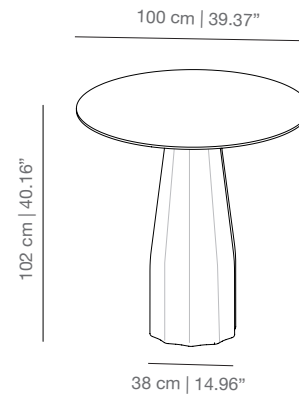

BUC70H 70x70

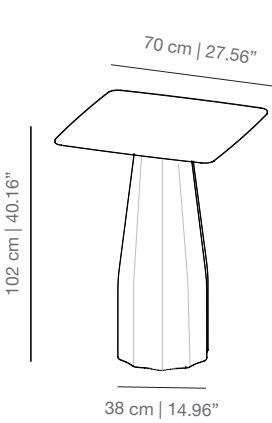

BUC80H 80x80

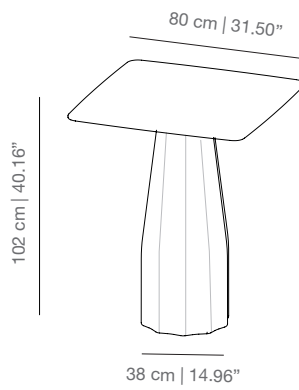

BUC90H 90x90

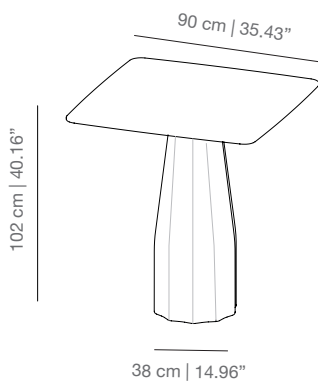

**TECHNICAL INFO**

The 30 mm thick cover or work surface is made with microtextured MDF. It is lacquered with one of our collection's finishes, making it very scratch resistant. It also comes with a solid oak veneer, stained in mate, wenge, cognac or ash. Available in high resistance materials such as HPL with MDF for heavy contract use.

**FINISHES**

**BASE**

Lacquered



white  
RAL 9003



black  
RAL 9005



sand  
NCS S3005Y50 R

**TOP**

Lacquered (microtexturized)



white  
RAL 9003



black  
RAL 9005



grey  
RAL 7004



tobacco  
RAL 8028



smoke  
RAL 1019



sand  
NCS S3005Y50 R



silver  
RAL 9006



red  
RAL 3001



mustard  
RAL 1012



green  
RAL 6007



blue  
RAL 5024

**Stained**



matt  
oak



wenge



cognac



ash

**LPL**



black



white

**Compact laminate**



white |  
white



black |  
black



white |  
black

**HPL**



black



white